

# SURFACE

# BKK9102

A white ribbed diffuser on a surface-mounted fixture providing soft, and even illumination.



- Standard ballast are electronic instant start for T8 lamp configurations
- The standard voltage is 120V, 60HZ, or as specified.

## FEATURES

- Conventional rounded vanity design
- White ribbed lens, for soft even glare free illumination
- One lamp cross section
- Ceiling mount or vertical or horizontal wall mount
- Suitable for individual mounting or may be connected together with a joiner band for continuous mounting \*(consult factory with row details for proper set-up)
- Available in lengths from 18" to 48"
- Suitable for indoor dry locations

## APPLICATIONS:

- Undercabinet
- Counters & Cabinets
- Kitchens
- Work stations
- Task lighting
- Merchandise displays furniture
- Closets

## OPTICS

- One piece acrylic white ribbed diffuser which allows for soft and even light output while concealing the lamp. Diffuser held securely in place by end caps. Easy access to the lamps is done by withdrawing end caps and acrylic lens

## OPTIONS

- Power cord w/molded plug (C)
- Rocker Switch (RS)
- Convenience outlet (R)
- Joiner Bands (JB)
- Emergency ballast (EM)

## ELECTRICAL

- Electronic ballasts : 120V, 120-277V, 347V
- All electrical components are UL approved/recognized
- Lamp holders which are provided ensure positive lamp retention

T8	
SIZE:	LENGTH:
(1) 15W	18 1/4"
(1) 17W	24 1/4"
(1) 25W	36 1/4"
(1) 32W	48 1/4"

## HOUSING

- Die formed heavy gauge cold rolled steel housing and end plates with a white enamel finish. A white enamel ballast cover/reflector removes easily for wiring access, while one-piece end caps fastens the diffuser while closing off the fixture.

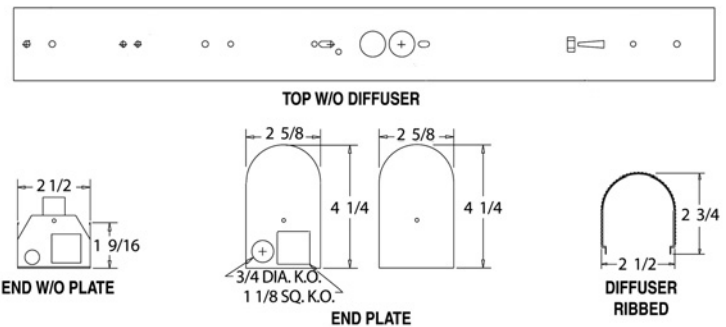

## ORDERING INFORMATION

SERIES	# LAMPS	WATTAGE	VOLTAGE	OPTIONS
BKK9102	1	15=15WT8 17=17WT8 25=25WT8 32=32WT8	120 UNV (120-277) 347	



Dimensions subject to change without notice. Certain configurations may not be available.

DATE	PROJECT NAME	MODEL	TYPE